

Technical Bulletin # 1025B

Product Description

PHILLYMASTIC TG-7B is a two-component, load-bearing, epoxy mastic specifically developed for LPG tank or container system installations where shimming or void-filling of supporting components is required. TG-7B provides excellent load-bearing and adhesive properties at cryogenic temperatures assuring evenly distributed loads across all tank supports. This mastic is available as either a liquid or a paste so it can be poured, pumped or troweled into place. Both the liquid and paste can be mixed either by hand or with automatic dispensing equipment.

Phillymastic TG-7B was designed to meet the requirements set forth by GAZ Transport's Technical Specification N. 402; Revision F issued in 1993.

Use & Benefits

LPG cargo tank containment systems are all self-supporting type tanks. This means that the cargo tank itself is separate from the vessel but installed inside the vessel. Self support tanks can be either the Free Standing Type (IMO Type B) or the Integrated Type (IMO Type C). See Fig. 1. Free-standing tanks are supported by pedestals and chocks mounted around the inside of the hull. The tanks can be either spherical or prismatic in their design. The Integrated Type tanks are installed inside the hull using tank saddles integrated in with the vessel's framing. These tanks tend to be spherical or bilobe in design.

Fig 1

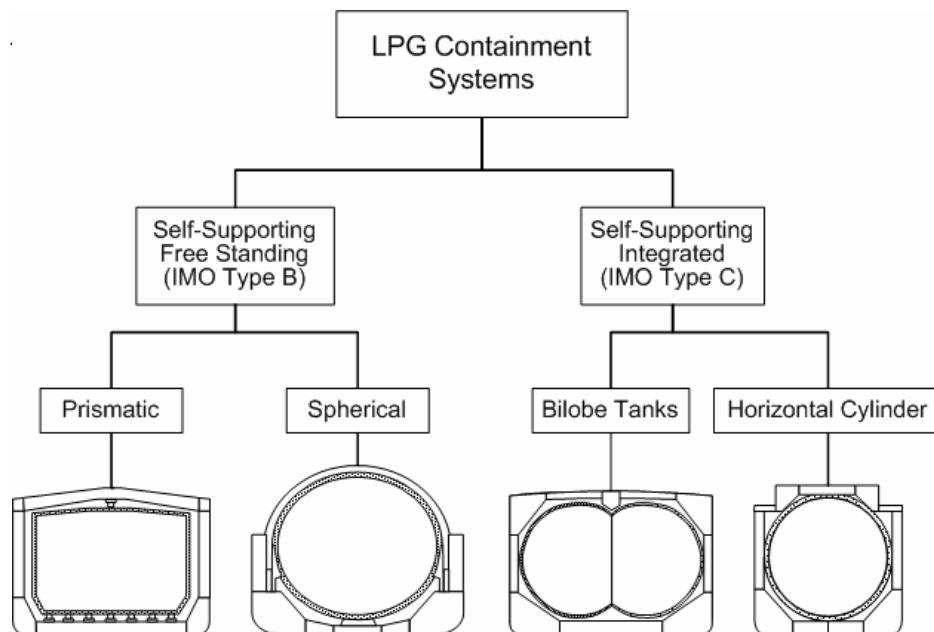

PHILLYMASTIC TG-7B is designed to be applied on or under the supports used in the mounting of all types LPG tanks including tank cradles, bottom support chocks, anti-rolling chocks and anti-pitching chocks.

PHILLYMASTIC TG-7B's load-bearing capability eliminates the need for fitting the wood blocks to precisely conform to the tank surface.

PHILLYMASTIC TG-7B is designed to easily withstand temperatures from -110°C to +40°C in addition to hydrocarbon vapors like methane, propane, butane, and ethane and liquids like seawater.

TG-7B paste is a non-sagging material is often applied by trowel on top of curved tank cradles before the tanks are set in position. In membrane type tanks, PHILLYMASTIC TG-7B can be applied directly on the secondary insulation or it can be used to adhere wood support members directly to the inner hull.

This mastic is designed to accommodate the thermal expansion requirements of tanks and contributes to the cumulative *K Factor*.

Preparation & Mixing Instructions

Determine the amount of PHILLYMASTIC TG-7B required to fill the void spaces or cover the area required. It is recommended that the volume estimate be increased by 10% to 15% to account for waste.

To facilitate mixing and applying, store PHILLYMASTIC TG-7B at 20° to 25°C (68° to 77°F) for 12 to 24 hours prior to mixing.

To mix either the paste or liquid, pour the entire contents of the hardener container into the slack-filled can of resin and power mix using a Jiffy Mixing blade at 200 to 300 RPM for 5 minutes. Make sure to scrape the side and bottom of the container with the mixing blade. Do not allow air to be drawn into the mixture. Let stand a few minutes to allow air to escape before installing.

To mix paste by hand, remove proper amounts of resin and hardener from containers and mix thoroughly with a putty knife on a clean flat surface.

All areas to receive the TG-7B should be clean and free of weld slag, water, dirt, oil, etc. Often damming is required around the area to prevent the mastic from leaking out. This is usually accomplished by installing self-adhesive strips of low compression rubber or foam around the area to be filled.

Installation Instructions

There are a number of LPG cargo tank construction methods. This Technical Bulletin was not meant to describe those methods in detail. Rather, this technical bulletin will provide examples of how PHILLYMASTIC TG-7B is used in some of the most common LPG tank designs.

Tank Saddle with a Sliding and Fixed Supports

There are two types of tank support saddles for cylindrical or spherical tanks – fixed and sliding. The fixed support anchors the tank while the sliding support allows the tank to expand and contract as needed.

In both the fixed and sliding supports, special laminated wood blocks are installed into the tank structure using TG-7B paste. The mastic paste is applied at a depth of about 10mm on top of the block and into the corners of the tank girdle. (Fig. 3) After the epoxy is applied, the tension on the strap is released and the block is set into position. This new block must be forced down

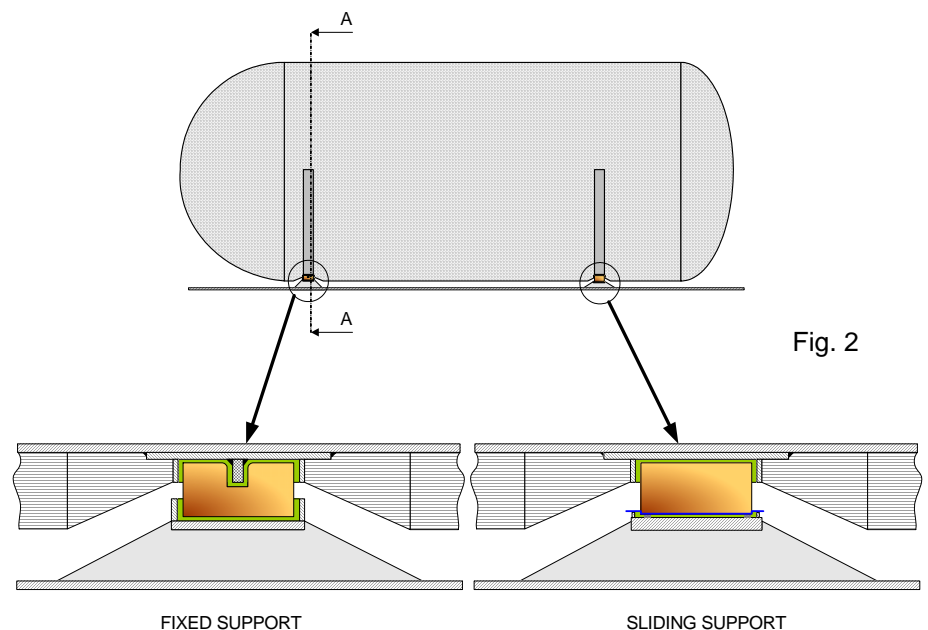

Fig. 2

tension on the strap is released and the block is set into position. This new block must be forced down

and tight against the preceding block. (Fig. 4) The strap is again tensioned and wood shoring installed to hold the block in place. (Fig. 5) Once all of the TG-7B has hardened, the strap can be removed and the wood blocks cleaned up and smoothed using a disc grinder.

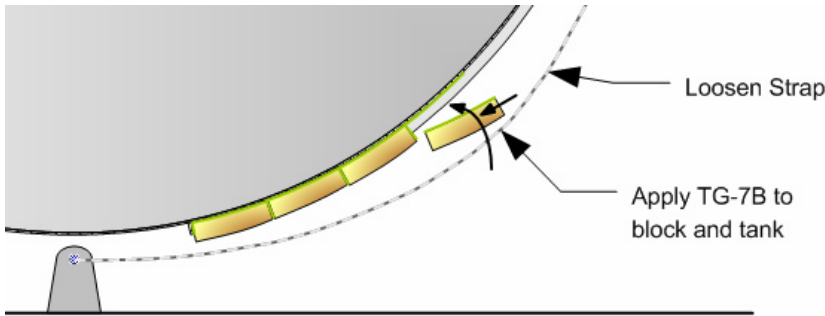

Fig. 4

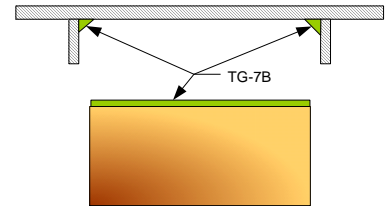

Fig. 3

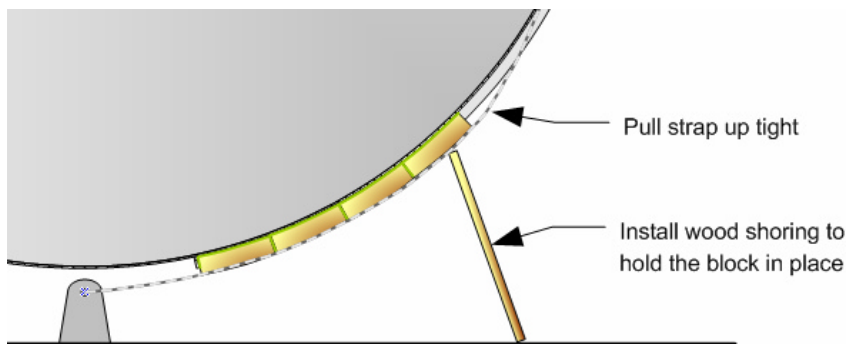

Fig. 5

After all of the blocks have been installed, smoothed and cleaned, the saddles are then prepared so the entire tank can be lowered into place inside the vessel. (Fig. 6) Both the forward and aft saddles must be prepared at the same time.

On fixed supports, TG-7B paste is mixed and applied using a trowel to the inside of the saddle support. At the top-most vertical end of the saddle, wood staves or batons can be installed across the saddle to prevent the mastic from sagging if needed. (Fig. 7) This is most often needed when the mastic is applied in thick sections or when it is applied in hot weather.

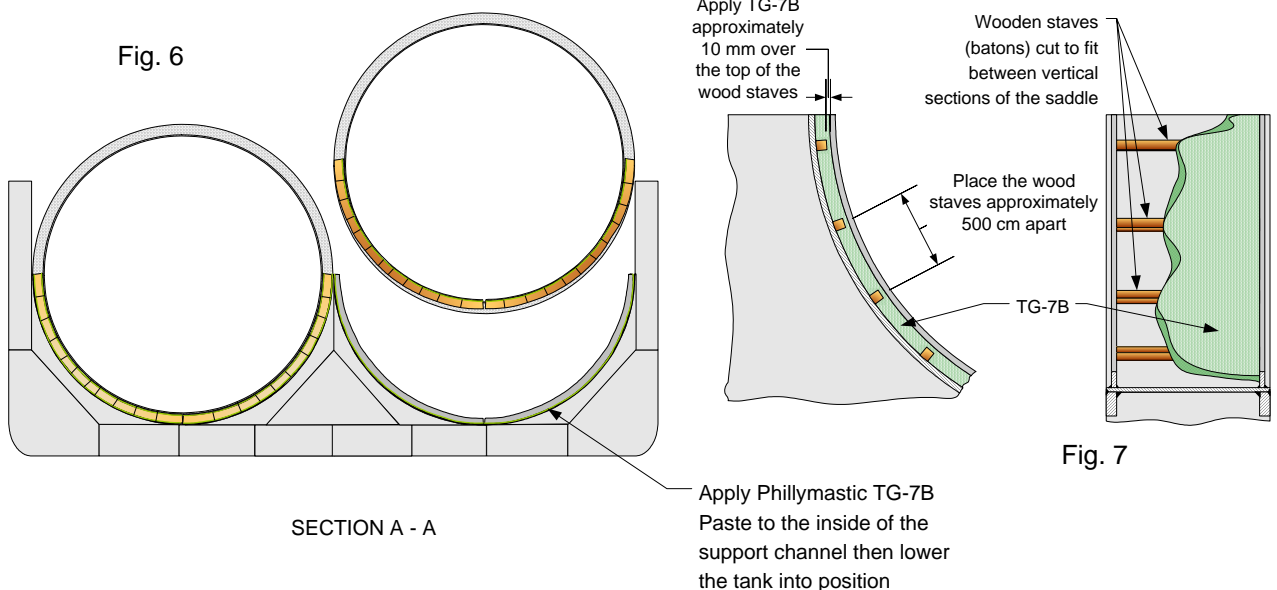

Fig. 7

These wood staves should be thinner than the total depth of the mastic so the TG-7B can be applied 10 mm over the top of the wooden staves.

Sliding supports must be constructed in such a way that they are free to move as the tank expands and contracts. One way to do this is to apply TG-7B to the saddle and cover it with a non-stick plastic sheet. In this way, the mastic will adhere tightly to the saddle and conform to the exact shape of wood blocks but not stick to them.

Start by installing adhesive-backed foam rubber strips to the surface of the saddle. The rubber strips should be 20 mm wide x 10 mm high and extend down the length of the saddle about 10 mm. from the steel side barns. Rubber strips can also be installed going across the saddle to help hold and level the mastic. Mix the TG-7B paste as directed and apply over the entire inside of the saddle up to the top of the rubber strips. Use the rubber strips as a guide to screed off extra TG-7B. When the mastic is evenly spread over the surface, cover the TG-7B with a 0.5 mm thick plastic sheet cut to fit over the saddles. Now lower the tank into position. As the weight of the tank pushes down on the TG-7B it will conform to the exact shape of the wood blocks. Some mastic may be squeezed and should be cleaned off.

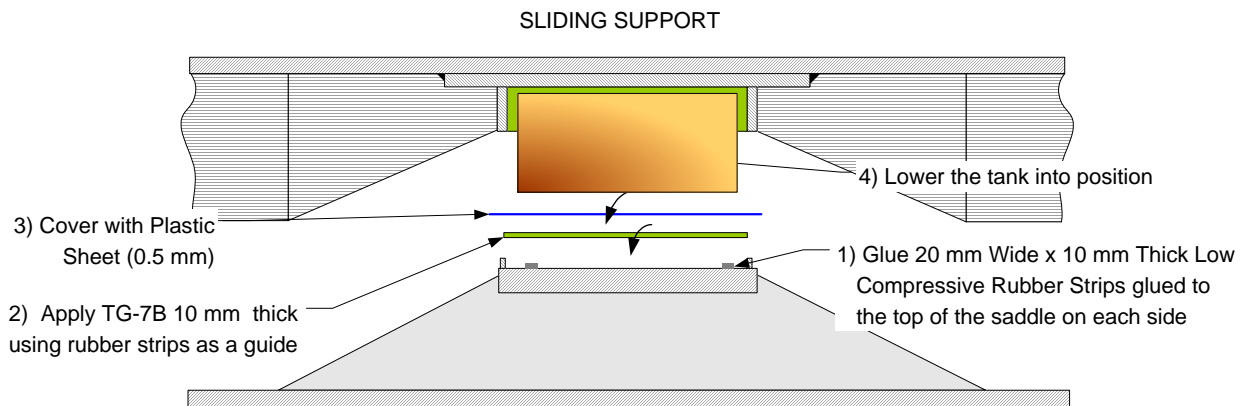

Fig. 8

Tank Support Chocks

Some self-support LPG tanks are rectangular or prismatic in shape. These tanks are support by chocks located under the tanks and are prevented from moving by chocks located on top or on the sides of the tank. Fig. 9 Chocks are typically constructed using a rectangular or square shaped steel foundation with a block of very dense wood or a wood / resin composite et in a well at the top of the foundation.

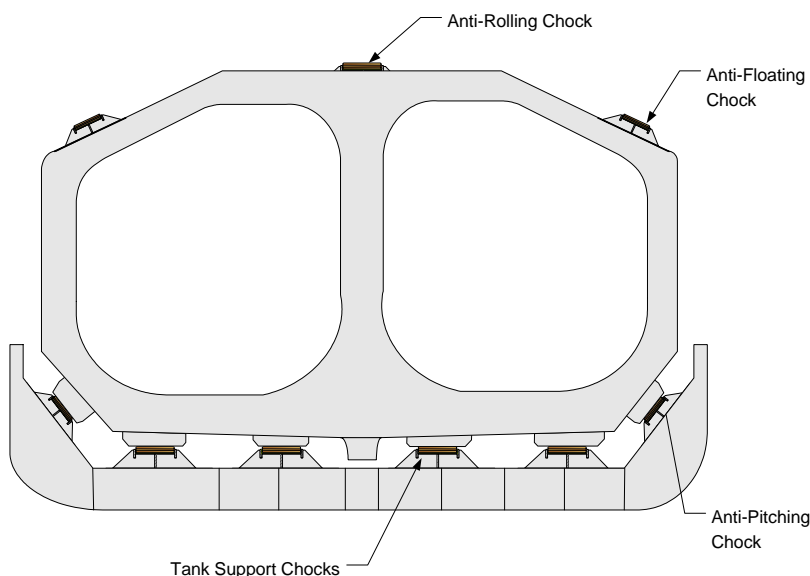

Fig. 9

The vessel's hull is first built with all of the tank supports located on top of the double bottom tanks. The wood blocks are set into each support and the tank is lowered down inside the vessel. The tank is positioned as required and the wood blocks are raise up to the bottom of the tank using jacking screws. Fig. 10 PHILLYMASTIC TG-7B liquid is then pumped under and around each block.

A positive displacement pump is connected through a series of hose with quick connect fittings, valves, and pipe fittings to the fill connections located under each support block. TG-7B is mixed

and pumped into the void space at the bottom and around the sides of the block until it comes out around the top. After the mastic has hardened, the jacking screws must be removed.

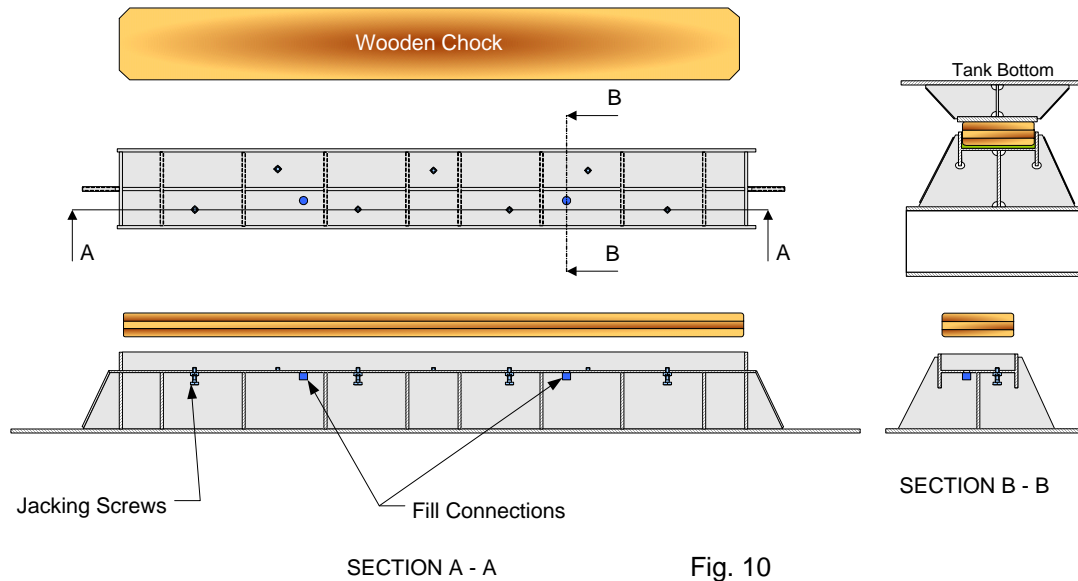
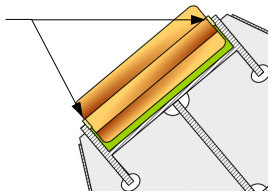

Fig. 10

Anti-rolling / Anti-pitching Chocks

Anti-rolling and anti-pitch chocks are similar in construction to the tank support chocks. The main difference is that they are usually located on an angle which requires additional damming to prevent the liquid TG-7B from coming out. Fig. 11 Open cell foam is inserted around the top of the opening between the block and the support. Open-cell foam allows the air to escape from under the block as the TG-7B enters.

Install Open-Cell foam damming around opening to prevent TG-7B from spilling out



Clean Up

If the TG-7B is still soft, cleanup of tools and equipment can be accomplished with soap and water. As the mastic cures it may be necessary to use an epoxy solvent such as IMPAX IXT-59.

Safety Precautions

PHILLYMASTIC TG-7B does not contain solvents and is not combustible so the mastic can be used without excessive ventilation. Some ventilation is recommended when working in closed quarters however.

The hardener component by itself is slightly corrosive. Protective clothing and rubber gloves are recommended when working with TG-7B. The mastic is completely inert and harmless after it is mixed and has cured.

Physical Properties at 20°C (68°F) unless otherwise stated

COMPRESSIVE STRENGTH	40 °C (104 °F) - 50.3 MPa (7,300 psi) 20 °C (68 °F) - 50.7 MPa (7,355 psi) -45 °C (-49 °F) - 112.8 MPa (16,538 psi)	ASTM D-695
COMPRESSIVE MODULUS OF ELASTICITY	40 °C (104 °F) - 1733 MPa (251 x 10 ³ psi) 20 °C (68 °F) - 3443 MPa (354 x 10 ³ psi) -45 °C (-49 °F) - 4038 MPa (586 x 10 ³ psi)	ASTM D-695
COEFFICIENT OF LINEAR THERMAL EXPANSION	20 °C to 196 °C - 29 x 10 ⁻⁶ mm/°C (0.63 x 10 ⁻⁷ in/°F)	
THERMAL CONDUCTIVITY	0.45 Wm °K (3.1 BTU in h ft ² °F)	
SHRINKAGE	0.2% by Volume	ASTM D-638

ADHESIVE BOND TO STEEL (with shop primer)	40 °C (104 °F) – 8.8 MPa (1,270 psi) 20 °C (68 °F) – 10.0 MPa (1,451 psi) -45 °C (-49 °F) – 7.3 MPa (1,064 psi) All samples failed at the adhesive to primer interface.	ASTM D-1002
ADHESIVE BOND TO BIRCH PLYWOOD	40 °C (104 °F) – 1.96 MPa (284 psi) 20 °C (68 °F) – 2.13 MPa (309 psi) -45 °C (-49 °F) – 1.96 MPa (284 psi) All samples were 100% plywood failure	ASTM D-1002
CREEP TEST OBSERVATION	0.011 to 0.053 inch/inch after 120 hours at 300 psi	
TENSILE ELONGATION	0.7% at failure	
HARDNESS	24 Barcol	ASTM D-2583
SPECIFIC GRAVITY	Paste – 1.6 Liquid – 1.66	
VISCOSITY – LIQUID TG-7B	Resin – 54,400 cps Liquid – 48 cps Mixed – 1,440 cps	
THIXOTROPY	A sample TG-7B paste 60 mm W x 100 mm L x 20 mm D placed vertically at 20 °C (68 °F) will not sag more than 10 mm before hardening	ASTM D-2730

Product Information at 20°C (68°F)

COVERAGE	Paste: Large Unit - 15,900 cm ³ (970 in ³) Paste: Small Unit - 208,000 cm ³ (12,693 in ³) Liquid – 17,200 cm ³ (1,050 in ³)
MIXING RATIOS	Paste – By Weight: 100g resin to 16.6 g hardener By Volume: 6 parts resin to 1 part hardener Liquid – By Weight: 100g resin to 4.9 g hardener By Volume: 11 parts resin to 1 part hardener
CURE TIME (approximate)	20 °C (68 °F) - 12 days 40 °C (104 °F) - 3 days 60 °C (140 °F) - 8 hours
POT LIFE	90 minutes @ 20°C
CLEAN UP	IMPAX IXT-59
PACKAGING per Unit	Paste: Large Unit - 15.9 liters (4.2 gal) Paste: Small Unit - 208 liters (55 gal) Liquid – 17.2 liters (4.6 gal)
UNIT WEIGHT	Paste – 25.4 kg (56 lbs) 334 kg (734 lbs) Liquid – 28.7 kg (63.1 lbs)
SHELF LIFE	2 years

Reference

For design considerations and application details please contact ITW Polymer Technologies' Engineering Services Department.

Date

04/2006

General: Every reasonable effort is made to insure the technical information and recommendations on these data pages are true and accurate to the best of our knowledge at the date of issuance. However, this information is subject to change without notice. Prior versions of this publication are invalid with the release of this version. Products and information are intended for use by qualified applicators that have the required background, technical knowledge, and equipment to perform said tasks in a satisfactory manner. Consult your local distributor for product availability, additional product information, and technical support.

Warranty: ITW Polymer Technologies, a division of Illinois Tool Works Inc., warrants that its products meet their printed specifications. This is the sole warranty. This warranty expires one year after product shipment.

Warranty Claims: If any product fails to meet the above, ITW Polymer Technologies will, at its option, either replace the product or refund the purchase price. ITW Polymer Technologies will have no other liability for breach of warranty, negligence, or otherwise. All warranty claims must be made in writing within one year of the date of shipment. No other claims will be considered.

Disclaimer: ITW Polymer Technologies makes no other warranty, expressed or implied, and specifically disclaims any warranty of merchantability or fitness for a particular purpose.

Suggestions concerning the use of products are not warranties. The purchaser assumes the responsibility for determining suitability of products and appropriate use. ITW Polymer Technologies' sole liability, for breach of warranty, negligence or otherwise, shall be the replacement of product or refund of the purchase price, at ITW Polymer Technologies' election. Under no circumstances shall ITW Polymer Technologies be liable for any indirect, incidental or consequential damages.

Modification of Warranty: No distributor or sales representative has the authority to change the above provisions. No change in the above provisions will be valid unless in writing and signed by an officer or the Technical Director of ITW Polymer Technologies. No term of any purchase order shall serve to modify any provision of this document.

Mediation and Arbitration: If any dispute arises relating to products or product warranties, either the purchaser or ITW Polymer Technologies may a) initiate mediation under the then current Center for Public Resources (CPR) Model Procedure for Mediation of Business Disputes, or b) initiate a non-binding arbitration under the rules of the American Arbitration Association for the resolution of commercial disputes.