

## INSTALLATION PROCEDURE FOR THE USE OF CHOCKFAST ORANGE WITH THRUST SLEEVES

### Summary

Wartsila NSD has designed thrust sleeves for their RTA series of engines that are intended to replace fitted bolts. The thrust sleeves are installed into fitted holes in the engine bed plate and into oversize holes in the ship's top plate. Chockfast Orange pourable epoxy chocking compound is poured around the thrust sleeves at the same time the chocks are poured. As a result, a tight fit is achieved for the thrust sleeves.

### Procedure

All standard procedures for using Chockfast Orange to chock the engine should be followed with the following additional procedures included:

1. After determining the location of the engine on the ship's foundation, drill holes at each hold down bolt location.
2. Holes for thrust sleeves should be drilled with a diameter of  $D_h$ .  $D_h$  should equal the outside diameter of the thrust sleeve,  $D_s$ , plus 10mm to 20mm. This will provide for a clearance around each thrust sleeve of 5mm to 10mm. See Figure 1.
3. Install the thrust sleeves into the holes. Apply a coating of Philadelphia Resins Release Agent to the surface of the thrust sleeves that will be in contact with Chockfast Orange. This can be accomplished by spraying up into the holes,  $D_h$ .
4. Insert a rubber sealing washer into each conical washer. Apply gasket sealer to the surface of the conical washers in contact with the ship's top plate.
5. Install a hold down bolt into each thrust sleeve and secure with nuts top and bottom. Tighten nuts hand tight.
6. Apply Chockfast according to standard procedures. Pour the Chockfast slowly at first to ensure epoxy fills the clearance space around the bottom of the thrust sleeves. See Figure 2.
7. Finish the work in accordance with standard procedures

**Genehmigt**

Approved

Hamburg

Ref.No.

10. 11. 98 \* 98 165 / 98

October 1998

**Germanischer Lloyd**

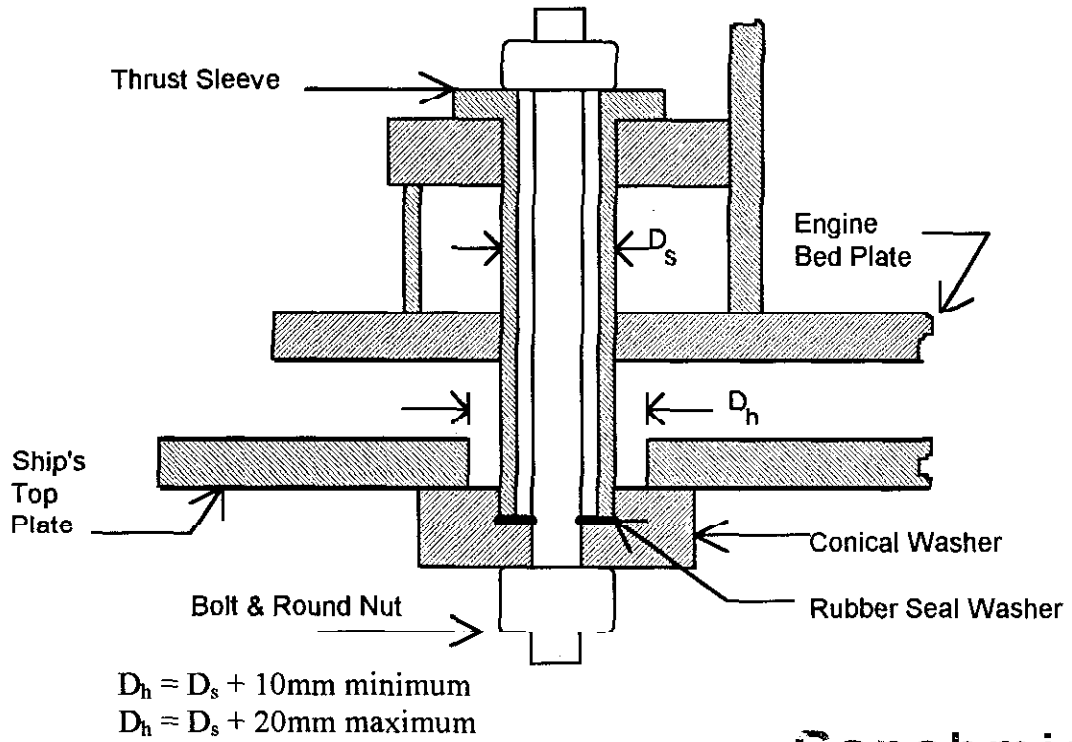

Figure 1

**Genehmigt**

Approved  
Hamburg Ref.No.

10. 11. 98 \* 98 165 / 98

**Germanischer Lloyd**

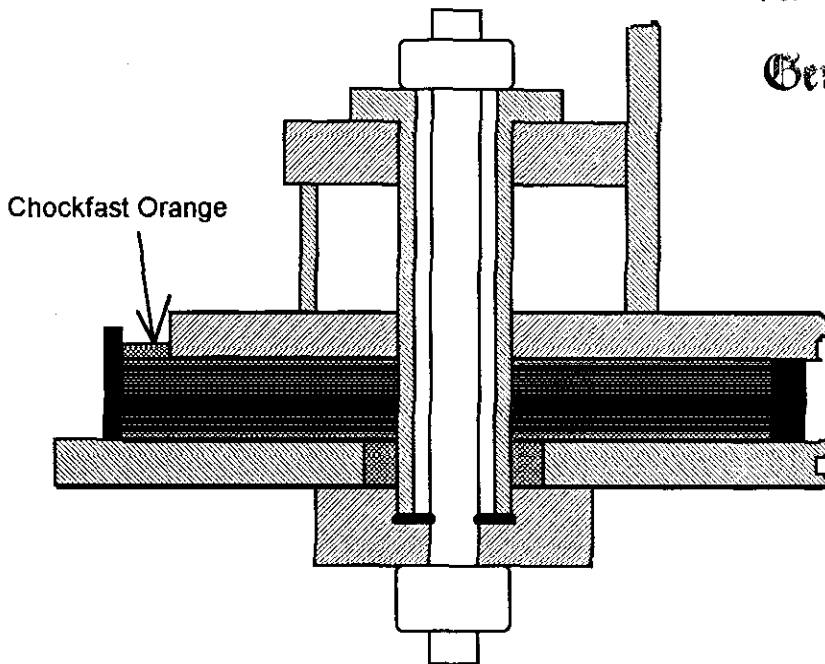

Figure 2