

INSTALLATION PROCEDURE FOR THE USE OF CHOCKFAST ORANGE WITH FITTED BOLTS

01.17.98 * 08810P / 98

© Germanischer Lloyd



Summary

Several engine manufacturers specify the use of fitted hold down bolts with their engine. This procedure describes how Chockfast Orange, a pourable epoxy chocking compound, may be used in place of fitting individual bolts.

Procedure

All standard procedures for using Chockfast Orange to chock the engine should be followed with the following additional procedures included:

1. The bolts must be designed by the shipyard or the engine manufacturer with reduced shaft diameter in the area not contacted by the Chockfast Orange. See Figure 1.
2. After determining the location of the engine on the ship's foundation, drill holes at each hold down bolt location.
3. The diameter of each bolt hole, d_h in both the ship's top plate and the engine bed plate, should equal the diameter of the hold down bolts, d_b , plus 10mm to 20mm. This will provide for a clearance around each bolt of 5mm – 10mm. See Figure 1. *It will not be necessary to ream the holes.*
4. Install a sealing O-Ring onto each bolt. The outside diameter of this O-Ring should be approximately 1mm larger than the diameter of the bolt hole, d_h .
5. Apply a coating of Philadelphia Resins Release Agent to each bolt and bolt hole in the areas that will be in contact with Chockfast Orange.
6. Install the hold down bolts in the center of each bolt hole.
7. Install the extension sleeves and nuts on each hold down bolt and snug them up by hand.
8. Apply Chockfast Orange according to standard procedures. Pour the Chockfast slowly at first to ensure epoxy fills the clearance space around the bolts in the ship's top plate.
9. Allow Chockfast Orange to cure. Remove nuts and extension sleeves and inspect the level of the Chockfast where it has risen up into the bolt holes.

9. The height of the Chockfast, h_{cf} , must be greater than the diameter of the bolt, d_b . See Figure 1.
10. If the level of the Chockfast is too low, additional material may be added at the top by injecting with a caulking gun. See Figure 2.

Genbright
Approved
Hampton Falls, NH

01. 12.98 * 10.9.98 P / 98

Genbright Resins



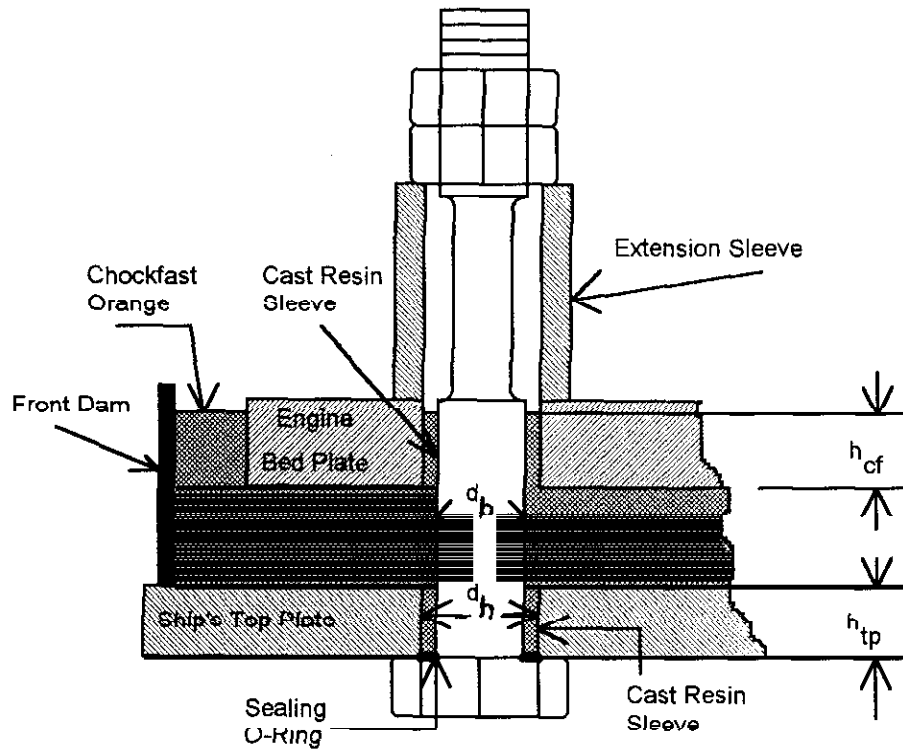

$d_h = d_b + 10 \text{ mm minimum}$
 $d_h = d_b + 20 \text{ mm maximum}$
 $h_{cf}, h_{tp} > d_b$

Figure 1

General Dynamics
 4000
 Hercules Part No.

01. 12.98 * P 0 8 1 8 P / 98

General Dynamics

[Handwritten signature]

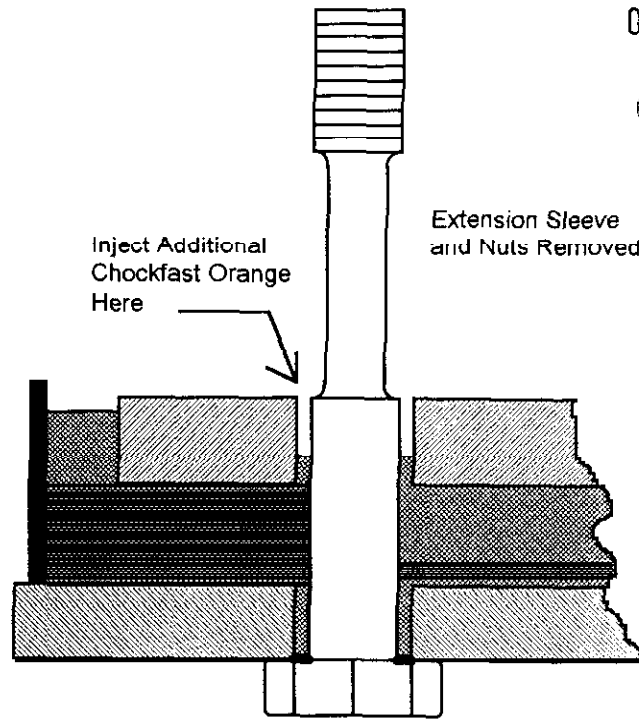

Figure 2